

MCB-100 WXD

Professional 40 Channel Mobile CB/Weather Radio

OWNER'S MANUAL



maxon[®]

A World of Communications

MCB-100 WXD SPECIFICATIONS

GENERAL

CB Channels:	40
Weather Channels:	10
CB Frequency Range:	26.965 to 27.405 MHz
Weather Frequency Range:	1 162.550 MHz
	2 162.400 MHz
	3 162.475 MHz
	4 162.425 MHz
	5 162.450 MHz
	6 162.500 MHz
	7 162.525 MHz
	8 161.650 MHz
	9 161.775 MHz
	0 163.275 MHz

CB/Weather

Frequency Control:	Phase Locked Loop Synthesizer
Operating Temperature:	-30° C to +50° C
Input Voltage:	13.8V DC nominal, negative or positive ground
Channel Display:	Light Emitting Diode (LED)
DC Input Power:	5 W
Dimensions:	7" W x 7-3/8" D x 2" H
Weight:	2 lbs., 9.3 oz.
External Speaker (optional):	4 W output @ 4 Ohms with 3.5 mm plug

RECEIVER

Receiving System:	AM Dual conversion superheterodyne
Audio Output Power:	4 W, 10% THD

TRANSMITTER

RF Output Power:	4 W (maximum FCC allowable)
Output Impedance:	50 Ohm unbalanced

Specifications are subject to change without notice.

PRODUCT DESCRIPTION

Thank you for choosing the Maxon MCB-100 WXD Professional 40 Channel Mobile CB/Weather Radio.

Maxon's MCB-100 WXD is designed for either in-dash or under/over dash installation, easy operation and is one of the most reliable 40 channel Citizens Band/ weather radios available.

Package Contents:

- Main CB unit
- Deluxe handheld microphone
- CB Unit and microphone mounting hardware
- In-dash mounting collar
- In-dash faceplate trim ring
- In-dash rear support mounting strap
- In-dash removal tools
- Under/over dash mounting bracket w/mounting hardware
- Owner's manual
- Copy of FCC Part 95, Subpart D
- NOAA Weather Radio Network frequency reference card

An external mobile antenna is required for use - antenna is not included. Refer to Mobile Antenna Information section for more information.

YOU DO NOT NEED AN FCC LICENSE TO OPERATE THIS RADIO IN THE UNITED STATES. However, you must know and be familiar with Part 95 of the FCC Rules in regard to Subpart D of the Citizens Band Radio Service. (A copy is enclosed with this unit).

Before operating your Maxon Citizens Band Radio, read this Owner's Manual carefully. If you have a problem, refer to the Troubleshooting section of this manual before returning your radio for repairs.

TABLE OF CONTENTS

Specifications	I
Product Description	II
Package Contents	II
FCC Regulations	II
Performance Features	1
Controls and Functions	2
Installation Instructions	4
In-Dash Installation	4
Removing the In-Dash CB Unit	6
Under/Over Dash Installation	7
DC Power Supply Connection	9
Negative Ground System Connection	9
Positive Ground System Connection	10
Mobile Antenna Information	11
Antenna Tuning/SWR Meter Operation	12
Calibrating the SWR Meter	12
Standing Wave Ratio Chart	14
Operating Instructions	15
For CB Operation	15
To Transmit/To Receive	16
External Speaker Operation	16
PA System and Optional PA Speaker Operation	16
Using the Weather Receiver	17
Weather Operation	17
Radio Communication Codes	19
CB Channel Frequency Chart	20
Troubleshooting Chart	21
Warranty Statement	22

PERFORMANCE FEATURES

- Multifunctional analog meter measures and displays the Standing Wave Ratio (SWR) of the CB antenna system; actual RF output power when transmitting; and input signal strength when receiving
- 40 CB Channels with 7 NOAA channels for receiving current local National Weather Service broadcasts and 3 periodic international marine weather channels
- Maximum legal output power (4 Watts)
- Dual mounting, for in-dash or under/over dash installation
- Direct access to Emergency CH 9 and Highway CH 19
- CB and weather channel selector knobs
- Dual-color LED identifies transmit and receive modes
- Public Address (PA) system circuitry (speaker not included)
- Automatic Noise Limiter (ANL) and noise blanker circuitry switch reduces atmospheric static noise interference during CB operation and reduces electrical impulse noise caused by the vehicle's ignition
- SWR Meter calibration capability
- RF Gain control knob adjusts the receiving sensitivity of the radio
- Front-mounted, deluxe microphone
- Display bright/dim switch
- Solid state components for years of trouble-free operation
- Highly sensitive, selective dual-conversion superheterodyne receiver with tuned RF stage
- Last channel memory recalls last channel displayed
- Rugged, metal cabinet
- One year warranty

CONTROLS AND FUNCTIONS

- A. **Microphone Jack**
 - B. **Off/ On-Volume Control**
 - C. **Squelch Control**
 - D. **RF Gain Control:** Adjusts the receiving sensitivity of the radio
 - E. **SWR Calibration Control:** Manually calibrates the SWR meter
 - F. **CB/WX Mode Selector:** Selects CB or weather operation
 - G. **CB/WX Channel Selector**
 - H. **LED Channel display:** Indicates the CB channel selected
 - I. **Weather (WX) LED Indicator:** Identifies weather mode
 - J. **Receive (RX)/Transmit (TX) LED Indicator:** Identifies radio status
 - K. **Display Bright / Dim Switch**
 - L. **CB-PA Switch:** Position selects normal CB operation or Public Address mode
 - M. **NB/ANL-ANL-OFF Switch:** Position selects noise blanker with automatic noise limiter circuitry; ANL circuitry only; or off
 - N. **CH 9-NOR-CH 19 Switch:** Position selects Emergency CH 9; normal CB channels (1-40); or Highway CH 19
 - O. **S/RF-SWR-CAL Switch:** Position selects function of analog meter: measuring radio input/output signal power strength; measuring Standing Wave Ratio of antenna; or entering SWR calibration mode
 - P. **Front-mounted, Deluxe Microphone**
 - Q. **Analog Meter:** Measures and displays the Standing Wave Ratio (SWR) of the CB antenna system; actual RF output power when transmitting; and input signal strength when receiving
- Antenna Pigtail Jack:** Located on back panel, not shown
- PA Speaker Jack:** Located on back panel, not shown
- External Speaker Jack:** Located on back panel, not shown
- DC Power Cord Jack:** Located on back panel, not shown

MOBILE CB RADIO



INSTALLATION INSTRUCTIONS

Your new MCB-100 WXD is designed to be installed in-dash, under/over the dash or anywhere INSIDE your vehicle. Safety and convenience should be your primary considerations in deciding exactly where to locate your CB radio.

CAUTION: Be sure the unit is located where it will not interfere with the driver or impair access to any controls necessary for the safe driving of the vehicle.

Before permanently installing the CB radio, connect the wiring temporarily and make sure it is connected properly and the CB unit is functioning. (Wiring instructions for power and antenna are located in this manual).

The radio's power and antenna connecting cables must be routed and secured in such a manner as not to interfere with the operation of the brake, accelerator or other controls. Interference from either the CB unit or its connecting cables may contribute to the loss of control of the vehicle.

Hardware is provided for in-dash or under/over dash installations. Use only the parts included with the CB unit to ensure proper installation. The use of unauthorized parts can cause malfunctions.

In-Dash Installation

In-dash installation requires the following provided hardware: mounting collar, front faceplate trim ring, rear metal mounting strap, and microphone hanger bracket.

The in-dash CB unit requires a rear support. Use the provided metal mounting strap (fig. 4) or a rear support bushing (not included).

DO NOT remove the factory pre-installed screws from the sides of the radio (fig. 1). They lock the CB unit securely into the mounting collar.

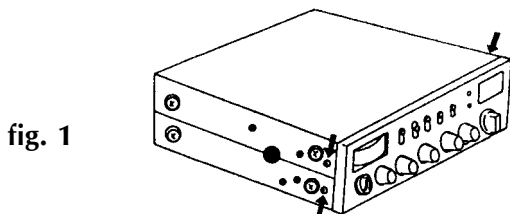

1. Before inserting the mounting collar into the dash, push the side tabs inward with a slight pressure (fig. 2a). Insert the mounting collar into the dashboard opening (fig. 2b). Select the proper tabs according to the thickness of the dashboard material (fig. 3) and bend them up slightly for a secure hold.

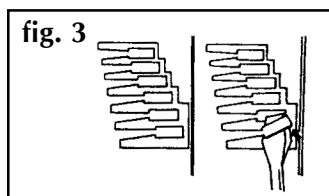
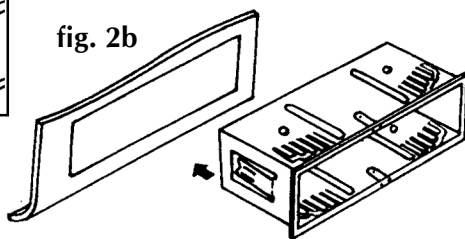
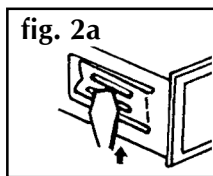

2. Connect power plug, external speaker, and mobile antenna cable and slide the CB unit into the mounting collar. The side tabs will expand and lock the CB unit into place. Secure rear support with provided metal mounting strap (fig. 4) or use a rear support bushing (not included).

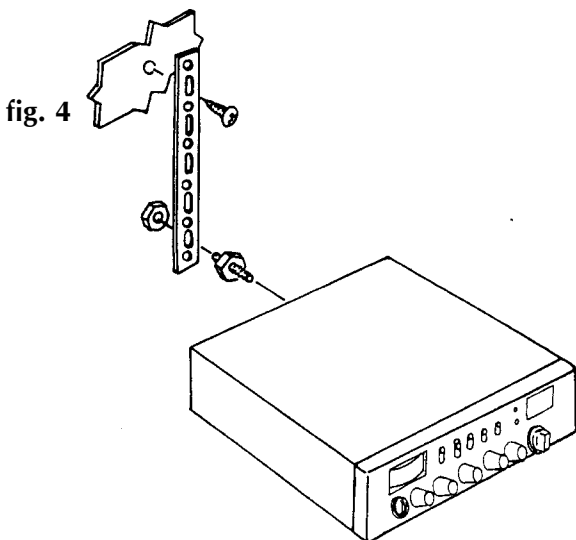

3. Install the front faceplate trim ring around the face of the CB unit. Insert the faceplate trim ring tabs into the grooves on the bottom of the CB unit. Then slide the top side of the faceplate trim ring back into position and snap tabs securely into grooves.
4. Mount the microphone hanger bracket wherever it is most convenient.

Removing the In-Dash CB Unit

1. Remove the front faceplate trim ring by lifting the tabs on the top of the trim ring out of the grooves in the CB unit. Then slide the faceplate trim ring down and off.

2. Use the provided tools for removal of the CB. Place one on each side of the unit with the notches and part numbers on the tools facing toward the CB. Insert the tools and push in until they click and lock, then gently but firmly pull the CB unit forward (fig. 5).

fig. 5

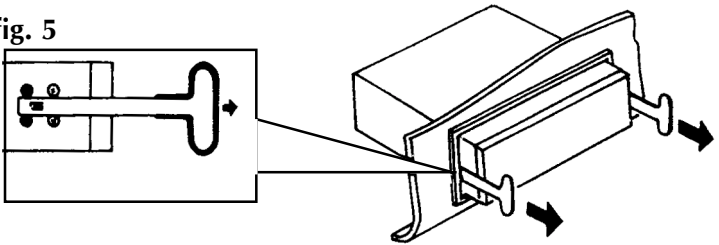

Under/Over Dash Installation

Under/over dash installation requires the following provided hardware: U-shaped mounting bracket, locking washers, retention knobs, microphone hanger bracket and self-tapping screws.

1. REMOVE the factory pre-installed screws on both sides of the CB unit (fig. 6).

fig. 6

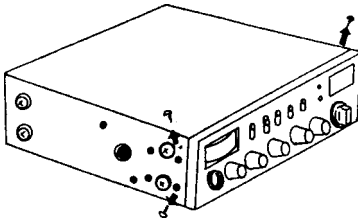

2. Install one locking washer on each side, with grooves facing away from the CB unit (fig. 7).

fig. 7

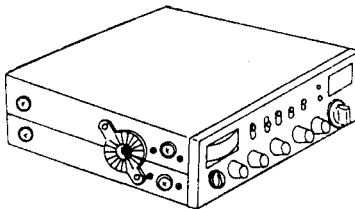

3. Determine the mounting location of the radio.
4. Use the U-shaped mounting bracket as a template for marking the location of the screw holes.

CAUTION: Extreme care should be exercised when drilling up into the dash to avoid damage to in-dash electronic ignition wiring, cruise control, instruments, air lines or accessory wiring.

5. Drill the necessary holes and secure the U-shaped mounting bracket with self-tapping screws (fig. 8).
6. Position the CB unit between the mounting bracket arms (fig. 8) and adjust to the desired viewing angle. Secure by tightening the two retention knobs.

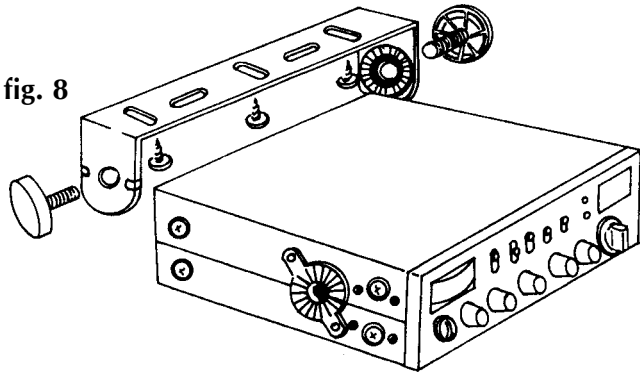

7. Install the microphone hanger bracket into the pre-drilled mounting holes on either side of the MCB-100 WXD cabinet **or** attach the bracket to the vehicle dash or any other convenient location.

NOTE: If you choose to mount the CB in a location where self-tapping screws cannot be used, determine the most secure method of fastening the U-shaped mounting bracket to that surface.

DC Power Supply Connection

The MCB-100 WXD is designed for 12V DC operation in vehicles with **negative (-) or positive (+) ground electrical systems.**

NOTE: Check your vehicle's ground requirements before you begin the radio installation.

Trace the battery cable (attached to the vehicle's frame) to the battery terminal post. If the battery terminal post is **marked with a minus (-) sign, it is a negative ground system.** If the battery terminal post is **marked with a plus (+) sign, it is a positive ground system.**

Negative Ground System

NEGATIVE GROUND WIRE
(FASTEN TO METAL BODY
OF VEHICLE)

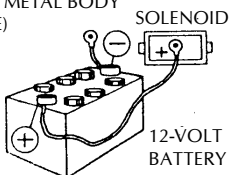

EXAMPLE OF NEG. GROUND 12V DC
BATTERY CONNECTION - MOST
COMMERCIAL VEHICLES ARE THIS TYPE.

Positive Ground System

POSITIVE WIRE (FASTEN TO METAL
BODY OF VEHICLE)

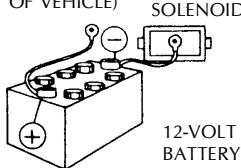

EXAMPLE OF POS. GROUND 12V DC
BATTERY CONNECTION - FEW
COMMERCIAL VEHICLES ARE THIS TYPE.

Your MCB-100 WXD should be connected using the following steps:

Place the on/off-volume knob in the off position by turning it counter-clockwise to detent. **Unplug your DC power cord.**

Negative Ground System Connection

1. Connect the **black** GROUND wire to a metal part of your vehicle's frame*.

NOTE: Be sure the metal part is not insulated from the vehicle's frame by a plastic part.

2. Connect the **red** (to switched accessory) wire to a source of voltage that turns on and off with the

ignition switch, such as a spare accessory terminal in your vehicle's fuse box.

3. Connect the **orange** (Batt +) wire to your vehicle's battery positive (+) terminal or to a point in the vehicle's fuse box that provides a continuous source of 12 Volts even when the ignition is turned off. This connection provides last channel memory feature.

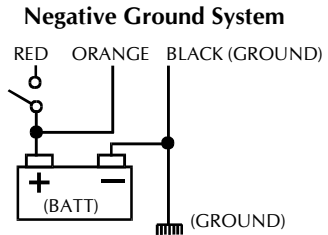

Positive Ground System Connection

1. Connect the **black** (Batt -) wire to your vehicle's battery negative (-) terminal or to a point in the vehicle's fuse box that provides a continuous source of 12 Volts even when the ignition is turned off.

NOTE: Be sure the metal part is not insulated from the vehicle's frame by a plastic part.

2. Connect the **red** (to switched accessory) wire to a source of voltage that turns on and off with the ignition switch, such as a spare accessory terminal in your vehicle's fuse box.

3. Connect the **orange** GROUND wire to a metal part of your vehicle's frame*. This connection provides last channel memory feature.

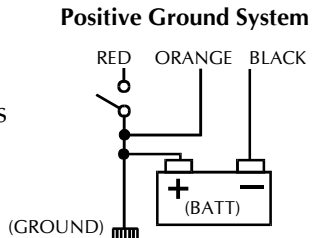

Reconnect the DC power cord to the DC jack.

* A good, direct metal-to-metal ground is essential for optimum performance. For the best ground connection, remove any paint, dust or grease from the grounding point.

MOBILE ANTENNA INFORMATION

Your Maxon MCB-100 WXD requires a vehicle mount CB/weather antenna for operation. An antenna is not included with your MCB-100 WXD because of varying vehicle applications, individual needs, and owner cost preferences.

You may use any standard 50 Ohm vehicle mount CB/weather antenna system with a PL-259 connector. Maxon antenna model WTA-4WP may be obtained from your local Maxon CB distributor/retailer.

NOTE: When installing a mobile antenna, please follow the antenna manufacturer's installation instructions completely. Never operate your CB radio without an antenna or with a broken antenna cable. This can result in internal damage to your CB circuitry.

- Connect the antenna securely to the unit's antenna receptacle
- Mount the antenna as high on the vehicle as possible - the more the antenna extends above the roof, the better the reception
- If possible, mount the antenna in the center of the surface you have chosen
- Keep the antenna cables away from noise sources such as the ignition system, gauges, etc.
- Make sure you have a solid, metal-to-metal ground

Antenna Tuning/SWR Meter Operation

Refer to the antenna manufacturer's installation manual for the recommended installation procedure and tuning specifications. Most antennas are factory tuned, however the radio's performance can usually be improved by slightly lengthening or shortening the antenna mast.

Optimum CB performance is obtained by tuning your antenna system to the actual frequency of the RF signal transmitted. Refer to the Standing Wave Ratio chart (following) to interpret the SWR meter readings.

For optimum performance, it is recommended that you tune the antenna's system to the most commonly used CB channel. If you have no particular channel preference, set your antenna's SWR for maximum performance for Highway Channel 19 operation.

You will obtain a different SWR reading from one CB channel to another. If you use all 40 CB channels, you may have 40 different SWR readings. Usually, almost all the CB transmissions will fall within an acceptable range.

Calibrating the SWR Meter

To calibrate the SWR meter, **place the S/RF-SWR-CAL switch into the CAL (calibration) position.** Using the handheld microphone, **press and hold the P-T-T bar on the side, and use the SWR CAL control knob** to manually adjust the analog meter to the CAL mark (the meter's top scale). **Release the P-T-T bar.** Now, **place the S/RF-SWR-CAL switch into the SWR position** for antenna tuning and performance measurements. **Press the mic's P-T-T bar and read the meter's SWR (top scale) for the antenna's actual SWR measurement.**

Prolonged antenna exposure to the elements (salt spray, humidity, corrosion, etc.) or vehicle vibration can cause degradation in performance. This may be indicated by a rise in the SWR meter's normal reading. Check the antenna's condition and the coaxial cable, RF electrical connections, etc. if a problem is indicated.

Standing Wave Ratio Chart

The ideal SWR reading is a 1:1 ratio, or a meter reading of 1 on the SWR meter's top scale (this is obtainable mostly under radio laboratory test conditions).

A 1.5:1 to 2:1 SWR ratio is excellent for most mobile CB antenna applications. Antenna installations in-the-field will probably show higher SWR meter readings.

SWR RATIOS	PERFORMANCE	
	RATING	DESCRIPTION
1:1 to 1.5:1	Superior	Perfect match between the antenna and cable length to the CB radio transmitter's RF output power.
1.5:1 to 2:1	Excellent	The antenna/cable system is an outstanding match with this CB transmitter's RF output power; ideal for most CB installations.
2:1 to 3:1	Good	The antenna/cable system with this CB transmitter will perform to spec under most normal conditions.
Higher than 3:1	Inefficient	Requires antenna system's mounting hardware or ground inspected; or the antenna system adjusted, or replaced.

OPERATING INSTRUCTIONS

Having properly installed and wired your new CB and connected the antenna, you are now ready to adjust your radio for optimum reception and voice transmission.

For proper operation, the radio's microphone must be connected to the unit. Insert the microphone plug into the microphone jack (MIC). Push inward and tighten the plug's locking nut.

NOTE: If you choose to remove the microphone and cord for storage, be sure to unscrew the locking nut then gently pull out the microphone plug to prevent damage to the microphone cord.

For CB Operation

1. Turn the power on and adjust the volume to the desired listening level. Set the CB-PA switch to the CB position, and the CB/WX mode selector knob to the CB mode position.

NOTE: Verify that the CH 9-NOR-CH 19 switch is in the NOR (normal) position, and the S/RF-SWR-CAL switch is set to S/RF.

2. Use the CB channel selector knob to select the desired channel. To use Emergency CH 9 or Highway CH 19, set the CH 9-NOR-CH 19 switch to the desired position.
3. To reduce undesirable background noise, select a channel where no signals are present, or wait until signals cease on your channel. Rotate the squelch control clockwise until the background noise ceases.

NOTE: When the squelch is set properly, the speaker will remain quiet until a signal is received. In order to receive weak signals, do not set the squelch too high.

4. Adjust the RF gain control to the desired level. In congested urban areas where reception interference is the greatest, reduce the RF gain. In rural or open country, increase the RF gain to improve the receiving sensitivity of incoming signals.

To Transmit/To Receive

Press and hold the push-to-talk bar. Speak slowly and clearly in a normal voice, two to three inches from the microphone. When transmitting, the RX/TX LED will glow red. **To Receive** - release the push-to-talk bar. When receiving or "standing by" the RX/TX LED will glow green.

External Speaker Operation

To connect an optional external speaker, locate the external speaker jack on the rear of the unit and insert the speaker plug into the jack. The radio's internal speaker will be silenced when an external speaker is engaged.

PA System and Optional PA Speaker Operation

To use the Public Address system feature, you must install a PA speaker outside of the vehicle. (This speaker is not supplied). After the speaker is installed and wires are properly connected to the PA jack, move the switch marked CB-PA to the PA position. At this time, CB operation will cease. You are now ready to broadcast through the PA system using the radio's microphone. You can adjust the external PA output volume with the radio's volume control knob. When finished, move the CB-PA switch back to the CB position.

Using The Weather Receiver

There are several special radio frequencies used by the National Weather Service throughout the United States to provide continuous reports of the local weather conditions and forecasts. Taped weather messages are repeated every four to six minutes on a 24-hour basis, and are routinely revised every one to three hours, or more frequently if needed.

During severe weather, the routine weather broadcasts will be interrupted with weather warning messages.

The MCB-100 WXD is designed to receive all seven NOAA weather frequencies as well as 3 periodic international marine weather frequencies. A frequency reference card of the National Oceanic and Atmospheric Administration (NOAA) Weather Radio Network is enclosed with your radio.

The MCB-100 WXD receives the following CB and National Weather Service frequencies:

CB Channels	1 - 40	26.965 to 27.405 MHz
Weather Channels	1	162.550 MHz
	2	162.400 MHz
	3	162.475 MHz
	4	162.425 MHz
	5	162.450 MHz
	6	162.500 MHz
	7	162.525 MHz
	8	161.650 MHz
	9	161.775 MHz
	0	163.275 MHz

Weather Operation

While unit is powered on, move the CB/WX mode selector to the WX position. Select the desired weather channel by using the CB/WX channel selector. Refer

to the NOAA Weather Radio Frequency card to locate the proper weather channel for your current geographic location. The WX LED will glow green when the weather receiver is active.

Re-adjust the volume if necessary.

To resume normal CB operation, simply turn the CB/WX selector to the CB position.

RADIO COMMUNICATION CODES

Citizens Band Radio operators have universally adopted the "10" Code for standard questions and answers. It enables them to communicate faster, easier and more understandably in noisy surroundings.

When using the code 10-1, you would say "Ten one" not "One zero one".

The following are some of the most common codes and their descriptions.

Code	Description	Code	Description
10-1	Receiving poorly.	10-36	Correct time is _____.
10-2	Receiving well.	10-37	Wrecker needed at _____.
10-3	Stop transmitting.	10-38	Ambulance needed at _____.
10-4	OK, message received.	10-39	Your message delivered.
10-5	Relay message.	10-41	Please turn to channel _____.
10-6	Busy, stand by.	10-42	Traffic accident at _____.
10-7	Out of service; leaving the air.	10-43	Traffic tie-up at _____.
10-8	In service, subject to call.	10-44	I have a message for you.
10-9	Repeat message.	10-45	All units within range report.
10-10	Transmission completed, standing by.	10-50	Break channel.
10-11	Talking too fast.	10-60	What is next message number?
10-12	Visitors present.	10-62	Unable to copy; use phone.
10-13	Advise weather/ road conditions.	10-63	Network directed to.
10-16	Make pickup at _____.	10-64	Network clear.
10-17	Urgent business.	10-65	Awaiting your next message/ assignment.
10-18	Anything for us?	10-67	All units comply.
10-19	Nothing for you; return to base.	10-70	Fire at _____.
10-20	My location is _____.	10-71	Proceed with transmission in sequence.
10-21	Call by telephone.	10-77	Negative contact.
10-22	Report in person to _____.	10-81	Reserve hotel room at _____.
10-23	Stand by.	10-82	Reserve room for _____.
10-24	Completed last assignment.	10-84	My telephone number is _____.
10-25	Can you contact?	10-85	My address is _____.
10-26	Disregard last information.	10-91	Talk closer to microphone.
10-27	I am moving to channel _____.	10-93	Check my frequency on this channel.
10-28	Identify your station.	10-94	Please give me a long count.
10-29	Time is up for contact.	10-99	Mission completed; all units secure.
10-30	Does not conform to FCC rules.	10-200	Police needed at _____.
10-32	I will give you a radio check.		
10-33	Emergency traffic.		
10-34	Trouble at this station.		
10-35	Confidential Information.		

CB CHANNEL FREQUENCY CHART

Channel:	1	26.965 MHz	
	2	26.975 MHz	
	3	26.985 MHz	
	4	27.005 MHz	
	5	27.015 MHz	
	6	27.025 MHz	
	7	27.035 MHz	
	8	27.055 MHz	
	9	27.065 MHz	Emergency Channel
	10	27.075 MHz	
	11	27.085 MHz	
	12	27.105 MHz	
	13	27.115 MHz	
	14	27.125 MHz	
	15	27.135 MHz	
	16	27.155 MHz	
	17	27.165 MHz	
	18	27.175 MHz	
	19	27.185 MHz	Highway Channel
	20	27.205 MHz	
	21	27.215 MHz	
	22	27.225 MHz	
	23	27.255 MHz	
	24	27.235 MHz	
	25	27.245 MHz	
	26	27.265 MHz	
	27	27.275 MHz	
	28	27.285 MHz	
	29	27.295 MHz	
	30	27.305 MHz	
	31	27.315 MHz	
	32	27.325 MHz	
	33	27.335 MHz	
	34	27.345 MHz	
	35	27.355 MHz	
	36	27.365 MHz	
	37	27.375 MHz	
	38	27.385 MHz	
	39	27.395 MHz	
	40	27.405 MHz	

TROUBLESHOOTING CHART

This CB radio has been manufactured in accordance with Maxon's exacting quality control standards. It should be handled with reasonable care. Avoid exposing it to dirt or moisture.

If you experience problems with your CB please refer to this Troubleshooting Chart.

POSSIBLE SOLUTIONS

POSSIBLE PROBLEM

	Check power cable connection	Check fuses (in-line and main junction block)	Check squelch adjustment	Check power on / off control	Change to active channel	Check antenna connection	Fully depress Push-To-Talk bar	Check microphone connection	Check CB/WX selector knob position
No sound or channel LED lights	●	●		●					●
Channel LED lights, but no sound			●		●	●		●	
No voice reception			●		●			●	●
Poor reception			●			●			
Unclear reception			●		●	●		●	
Transmission problems						●	●	●	●

WARNING: DO NOT ATTEMPT TO MAKE ANY INTERNAL ADJUSTMENTS. Any internal adjustments must be made only by qualified technical personnel. Internal adjustments and/or modifications can lead to illegal operation as defined by FCC Rules and Regulations, Part 95. Illegal operation can result in serious consequences.

CAUTION: The fuse included with this unit is an important safety feature which must **not** be circumvented. **Removal of this fuse or the use of a fuse rated higher than supplied may result in overheating and/or fire and consequential damage to the unit or vehicle.** If a replacement fuse burns out, have the unit inspected and repaired by a qualified service technician.

LIMITED WARRANTY STATEMENT

The Consumer Products Division of Maxon America, Inc., (hereinafter referred to as "Maxon"), warrants that its Products and their included accessories will be free from defects in workmanship or materials under normal use for a period of one (1) year from date of purchase by the original end user, provided that the buyer has complied with the requirements stated herein.

If the Product fails to function under normal use because of manufacturing defect(s) or workmanship during the one (1) year period following the date of purchase, it will be replaced or repaired at Maxon's option at no charge when returned to the place of purchase. The defective unit must be accompanied by proof of the date of purchase in the form of a sales receipt.

Maxon's sole obligation hereunder shall be to replace or repair the product covered in this Warranty. Replacement, at Maxon's option, may include a similar or higher-featured product. Repair may include the replacement of parts or boards with functionally equivalent reconditioned or new parts or boards. Replaced parts, accessories, batteries or boards are warranted for the balance of the original time period. All replaced parts, accessories, batteries or boards become the property of Maxon America, Inc.

Maxon shall have no obligation to make repairs or to cause replacement required which result from normal wear and tear or is necessitated in whole or in part by catastrophe, the fault or negligence of the user, improper or unauthorized alterations, repairs to the Product, incorrect wiring, use of the Product in a manner for which it was not designed, or by causes external to the Product. This warranty is void if the serial number is altered, defaced or removed.

The purchaser shall provide for removal of the defective Product and installation of its replacement.

THE EXPRESS WARRANTIES CONTAINED HEREIN ARE IN LIEU OF ALL OTHER WARRANTIES, EITHER EXPRESSED OR IMPLIED OR STATUTORY, INCLUDING, WITHOUT LIMITATION, ANY WARRANTY OF MERCHANTABILITY OR FITNESS FOR A PARTICULAR PURPOSE.

FOR ANY PRODUCT WHICH DOES NOT COMPLY WITH THE WARRANTY SPECIFIED, THE SOLE REMEDY WILL BE REPAIR OR REPLACEMENT. IN NO EVENT WILL MAXON AMERICA, INC. BE LIABLE TO THE BUYER OR ITS CUSTOMERS FOR ANY DAMAGES, INCLUDING ANY SPECIAL, INCIDENTAL, INDIRECT OR CONSEQUENTIAL DAMAGES, OR THE LOSS OF PROFIT, REVENUE OR DATA ARISING OUT OF THE USE OF OR THE INABILITY TO USE THE PRODUCT.

This warranty is void for sales and deliveries outside of the U.S.A.

Thank you for choosing Maxon!

For more information, contact:

**Maxon America, Inc.
Consumer Products Division
10828 NW Air World Drive
Kansas City, Missouri 64153**

Phone: 1-800-821-7848, Ext. 399

Fax: 816/891-8815

or explore our website: www.maxonusa.com