

Professional Digital Two-Way Radio System

# MOTOTRBO™ DM 3400 / DM 3401 Numeric Display Mobile

User Guide



# Contents

This User Guide contains all the information you need to use the MOTOTRBO Series Mobiles.

<b>Important Safety Information</b> .....	<b>iii</b>
Product Safety and RF Exposure Compliance .....	iii
<b>Computer Software Copyrights</b> .....	<b>iv</b>
<b>Getting Started</b> .....	<b>1</b>
How to Use This Guide .....	1
What Your Dealer/System Administrator Can Tell You .....	1
Powering Up the Radio .....	2
Adjusting the Volume .....	2
<b>Identifying Radio Controls</b> .....	<b>3</b>
Radio Controls You Will Be Using .....	3
Programmable Buttons .....	4
Assignable Radio Functions .....	4
Assignable Settings/Utility Functions .....	4
Push-To-Talk (PTT) Button .....	5
Switching Between Analog and Digital Mode .....	5

<b>Identifying Status Indicators</b> .....	<b>6</b>
Display Icons .....	6
LED Indicators .....	6
Audio Tones .....	7
Indicator Tones .....	7
<b>Receiving and Making Calls</b> .....	<b>8</b>
Selecting a Zone .....	8
Selecting a Radio Channel, Subscriber ID, or Group ID .....	8
Receiving and Responding to a Voice Call .....	8
Receiving and Responding to a Group Call .....	9
Receiving and Responding to a Private Call .....	9
Receiving an All Call .....	10
Making a Voice Call .....	10
Making a Voice Call with the Channel Rocker .....	10
Making a Group Call .....	10
Making a Private Call .....	11
Making an All Call .....	11
Making a Group or Private Call with the One Touch Call Button .....	11
Talkaround .....	12
Permanent Monitor .....	12

**Advanced Features** ..... **13**

- Scan Lists ..... 13
- Scan ..... 13
  - Starting and Stopping Scan ..... 14
  - Responding to a Transmission During  
a Scan ..... 14
  - Deleting a Nuisance Channel ..... 14
  - Restoring a Nuisance Channel ..... 14
- Call Indicator Settings ..... 15
  - Escalating Alarm Tone Volume ..... 15
- Call Alert Operation ..... 15
  - Receiving and Acknowledging a Call Alert ..... 15
  - Making a Call Alert with the One Touch Call  
Button ..... 15
- Emergency Operation ..... 16
  - Sending an Emergency Alarm ..... 16
  - Sending an Emergency Alarm with Call ..... 16
  - Sending an Emergency Alarm with  
Voice to Follow ..... 17
  - Reinitiating an Emergency Mode ..... 17
  - Exiting an Emergency Mode ..... 18

- Text Messaging Features ..... 18
  - Sending a Quick Text Message ..... 18
- Utilities ..... 19
  - Setting the Squelch Level ..... 19
  - Setting the Power Level ..... 19
  - Turning Horns/Lights On or Off ..... 20
  - Turning Radio Tones/Alerts On or Off ..... 20

# Important Safety Information

## Product Safety and RF Exposure Compliance



Caution

Before using this product, read the operating instructions for safe usage contained in the Product Safety and RF Exposure booklet enclosed with your radio.

## ATTENTION!

**This radio is restricted to occupational use only to satisfy FCC RF energy exposure requirements.** Before using this product, read the RF energy awareness information and operating instructions in the Product Safety and RF Exposure booklet enclosed with your radio (Motorola Publication part number 6866537D37) to ensure compliance with RF energy exposure limits.

For a list of Motorola-approved antennas and other accessories, visit the following website:

<http://www.motorola.com/governmentandenterprise>

## Computer Software Copyrights

The Motorola products described in this manual may include copyrighted Motorola computer programs stored in semiconductor memories or other media. Laws in the United States and other countries preserve for Motorola certain exclusive rights for copyrighted computer programs including, but not limited to, the exclusive right to copy or reproduce in any form the copyrighted computer program. Accordingly, any copyrighted Motorola computer programs contained in the Motorola products described in this manual may not be copied, reproduced, modified, reverse-engineered, or distributed in any manner without the express written permission of Motorola. Furthermore, the purchase of Motorola products shall not be deemed to grant either directly or by implication, estoppel, or otherwise, any license under the copyrights, patents or patent applications of Motorola, except for the normal non-exclusive license to use that arises by operation of law in the sale of a product.

The AMBE+2™ voice coding Technology embodied in this product is protected by intellectual property rights including patent rights, copyrights and trade secrets of Digital Voice Systems, Inc.

This voice coding Technology is licensed solely for use within this Communications Equipment. The user of this Technology is explicitly prohibited from attempting to decompile, reverse engineer, or disassemble the Object Code, or in any other way convert the Object Code into a human-readable form.

U.S. Pat. Nos. #5,870,405, #5,826,222, #5,754,974, #5,701,390, #5,715,365, #5,649,050, #5,630,011, #5,581,656, #5,517,511, #5,491,772, #5,247,579, #5,226,084 and #5,195,166.

## Getting Started

Take a moment to review the following:

How to Use This Guide . . . . .	page 1
What Your Dealer/System Administrator Can Tell You . . . . .	page 1
Powering Up the Radio . . . . .	page 2
Adjusting the Volume. . . . .	page 2

### ■ How to Use This Guide

This User Guide covers the basic operation of the MOTOTRBO Mobiles with Numeric Display.

However, your dealer or system administrator may have customized your radio for your specific needs. Check with your dealer or system administrator for more information.

Throughout this publication, two icons are used to differentiate Analog mode and Digital mode only features:



Indicates an Analog mode only feature.



Indicates a Digital mode only feature.

For features that are available in both Analog and Digital modes, no icon is shown.

### ■ What Your Dealer/System Administrator Can Tell You

You can consult your dealer or system administrator about the following:

- Is your radio programmed with any preset conventional channels?
- Which buttons have been programmed to access other features?
- What optional accessories may suit your needs?

## ■ Powering Up the Radio

Press the On/Off Button briefly.

The green LED blinks and the numeric display screen lights up.

A brief tone sounds, indicating that the power up test is successful.

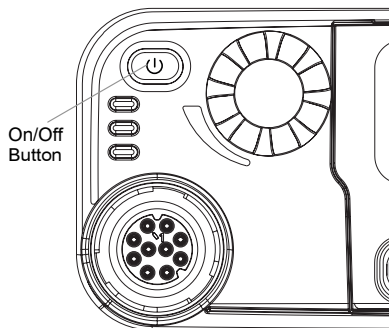

**NOTE:** There is no power up tone if the radio tones/alerts function is disabled (see **Turning Radio Tones/Alerts On or Off** on page 20).

If your radio does not power up, contact your dealer.

*To turn off the radio, press and hold the On/Off Button.*

## ■ Adjusting the Volume

To increase the volume, turn the **Volume Knob** clockwise.

*To decrease the volume, turn this knob counterclockwise.*

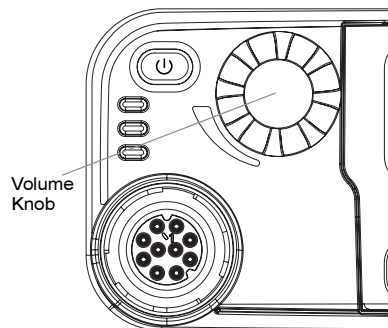

## Identifying Radio Controls

Take a moment to review the following:

Radio Controls You Will Be Using . . . . .	page 3
Programmable Buttons . . . . .	page 4
Push-To-Talk (PTT) Button . . . . .	page 5
Switching Between Analog and Digital Mode . . . . .	page 5

### ■ Radio Controls You Will Be Using

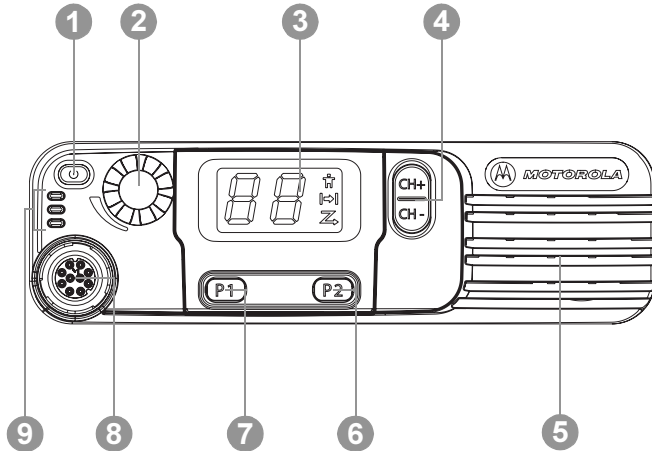

- 1 On/Off Button
- 2 Volume Knob
- 3 Display
- 4 Channel Rocker
- 5 Speaker
- 6 Front Button P2\*
- 7 Front Button P1\*
- 8 Accessory Connector
- 9 LED Indicators

*\* These buttons are programmable.*



## ■ Programmable Buttons

---

Your dealer can program the programmable buttons as shortcuts to radio functions or preset channels/groups depending on the duration of a button press:

- Press – Pressing and releasing rapidly.
- Long press – Pressing and holding for the preprogrammed duration (between 0.25 seconds and 3.75 seconds).
- Hold down – Keeping the button pressed.

### Assignable Radio Functions

**Emergency** – Depending on the programming, initiates or cancels an Emergency Alarm or Call.

**Nuisance Channel Delete** – Temporarily removes an unwanted channel, except for the Selected Channel, from the scan list. The Selected Channel refers to the user's selected zone/channel combination from which scan is initiated.

**One Touch Call**  – Directly initiates a predefined Group or Private Call, a Call Alert or a Quick Text message.

**Permanent Monitor** – Monitors a selected channel for all radio traffic until function is disabled.

**Repeater/Talkaround** – Toggles between using a repeater and communicating directly with another radio.

**Scan** – Toggles scan on or off.

**Telemetry Control**  – Controls the Output Pin on a local or remote radio.

**Zone** – Allows selection from a list of zones.

### Assignable Settings/Utility Functions

**All Tones/Alerts** – Toggles all tones on or off.

**Power Level** – Toggles transmit power level between high and low.

**Squelch**  – Toggles squelch level between normal and tight.

## ■ Push-To-Talk (PTT) Button

The PTT button on the side of the microphone serves two basic purposes:

- While a call is in progress, the PTT button allows the radio to transmit to other radios in the call.

Press and hold down PTT button to talk. Release the PTT button to listen.

The microphone is activated when the PTT button is pressed.

- While a call is not in progress, the PTT button is used to make a new call (see **Making a Voice Call** on page 10).

 Depending on programming, if the Talk Permit Tone is enabled, wait until the short alert tone ends before talking.

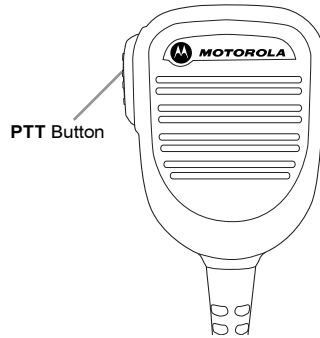

## ■ Switching Between Analog and Digital Mode

Each channel in your radio can be configured as an analog channel or a digital channel. Use the Channel Rocker to switch between an analog or a digital channel.

When switching from digital to analog mode, certain features are unavailable.

Your radio also has features available in both analog and digital mode. However, the minor differences in the way each feature works does **NOT** affect the performance of your radio.

**NOTE:** Your radio also switches between digital and analog modes during a dual mode scan (see **Scan** on page 13).

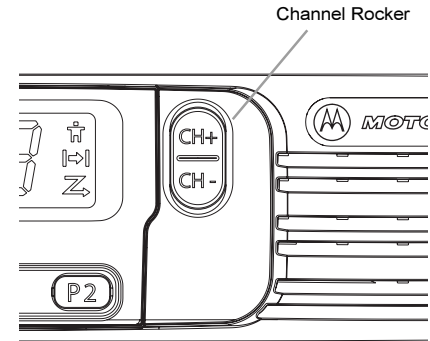

## Identifying Status Indicators

Your radio indicates its operational status through the following:

LED Indicators . . . . .	page 6
Audio Tones . . . . .	page 7
Indicator Tones . . . . .	page 7

### ■ Display Icons

The seven-segment display shows radio channel and status.

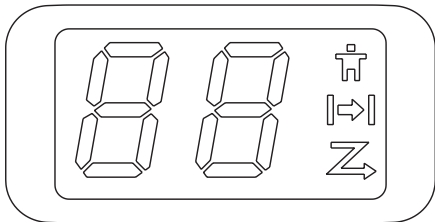

The following are the icons that appear on the radio's display.



#### Private Call

Indicates a Private Call in progress.



#### Talkaround

In the absence of a repeater, radio is currently configured for direct radio to radio communication.



#### Scan

Scan feature is activated.

### ■ LED Indicators

LED indicators show the operational status of your radio.

**Blinking red** – Radio is receiving an emergency transmission or has failed the self-test upon powering up.

**Solid yellow** – Radio is receiving a request for a Private Call, or monitoring a channel.

**Blinking yellow** – Radio is scanning for activity or receiving a Call Alert.

**Solid green** – Radio is transmitting.

**Blinking green** – Radio is powering up or receiving a call.

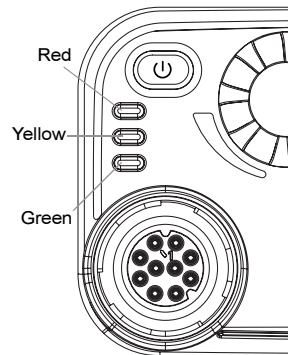

## ■ Audio Tones

---

Alert tones provide you with audible indications of the radio's status or the radio's response to data received.

**Continuous Tone** A monotone sound. Sounds continuously until termination.



**Periodic Tone** Sounds periodically depending on the duration set by the radio. Tone starts, stops and repeats itself.



**Repetitive Tone** A single tone that repeats itself until it is terminated by the user.



**Momentary Tone** Sounds only once for a short period of time defined by the radio.



## ■ Indicator Tones

---

High pitched tone

Low pitched tone



Positive Indicator Tone



Negative Indicator Tone

## Receiving and Making Calls

Once you understand how your MOTOTRBO Mobile is configured, you are ready to use your radio.

Use this navigation guide to familiarize yourself with the basic Call features:

- Selecting a Zone ..... page 8
- Selecting a Radio Channel, Subscriber ID, or Group ID ..... page 8
- Receiving and Responding to a Voice Call ..... page 8
- Making a Voice Call ..... page 10
- Talkaround ..... page 12
- Permanent Monitor ..... page 12

### Selecting a Zone

A zone is a group of channels. Your radio supports up to a maximum of 2 zones.

**Procedure:**

- 1 Press the preprogrammed **Zone** button.
- 2 You hear a positive indicator tone, indicating the radio has switched from Zone 1 to Zone 2.  
**OR**  
You hear a negative indicator tone, indicating the radio has switched from Zone 2 to Zone 1.

### Selecting a Radio Channel, Subscriber ID, or Group ID

**Procedure:**

Once the required zone is set (if you have multiple zones in your radio), press the Channel Rocker to select the number that represents the channel, subscriber ID, or group ID.

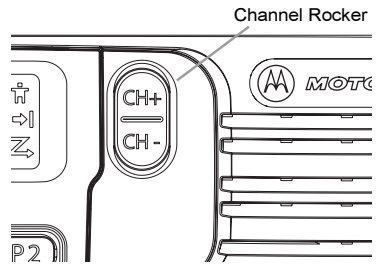

### Receiving and Responding to a Voice Call

Once the channel, subscriber ID, or group ID is set, you can proceed to receive and respond to calls.

*The green LED lights up while the radio is transmitting and blinks when the radio is receiving.*

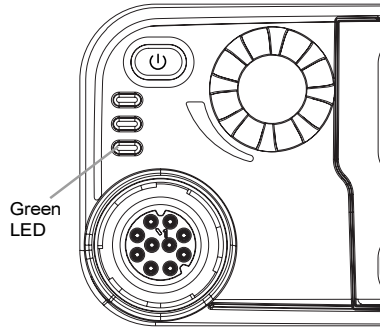

## Receiving and Responding to a Group Call

To receive a call from a group of users, your radio must be configured as part of that group.

### Procedure:

When you receive a Group Call:

- 1 The green LED blinks.

---

- 2 Press the **PTT** button to respond to the call. The green LED lights up.

---

- 3 Wait for the Talk Permit Tone to finish (if enabled) and speak clearly into the microphone.

---

- 4 Release the **PTT** button to listen.

---

- 5 If there is no voice activity for a predetermined period of time, the call ends.

See **Making a Group Call** on page 10 for details on making a Group Call.

## Receiving and Responding to a Private Call

A Private Call is a call from an individual radio to another individual radio.

There are two types of Private Calls. The first type, where a radio presence check is performed prior to setting up the call, while the other sets up the call immediately.

When your radio is checked, the yellow LED lights up momentarily. Only one of these call types can be programmed to your radio by your dealer.

### Procedure:

When you receive a private call:

- 1 Depending on how your radio is programmed:  
The yellow LED lights up momentarily. Then, the green LED blinks.  
**OR**  
The green LED blinks.

---

- 2 Press the **PTT** button to respond to the call. The green LED lights up.

---

- 3 Wait for the Talk Permit Tone to finish (if enabled) and speak clearly into the microphone.

- 4 Release the **PTT** button to listen.

---

- 5 If there is no voice activity for a predetermined period of time, the call ends.

---

- 6 You hear a short tone.

---

See **Making a Private Call** on page 11 for more details on making a private call.

### **Receiving an All Call**

An All Call is a call from an individual radio to every radio on the channel. It is used to make important announcements requiring the user's full attention.

#### **Procedure:**

When you receive an All Call:

- 1 A tone sounds and the green LED blinks.

---

- 2 If there is no voice activity for a predetermined period of time, the All Call ends.

---

*You cannot respond to an All Call.*

**NOTE:** The radio stops receiving the All Call if you switch to a different channel while receiving the call.  
During an All Call, you will **not** be able to use any preprogrammed button functions until the call ends.

## ■ **Making a Voice Call**

---

You can select a channel, subscriber ID or group by using:

- Channel Rocker
- a preprogrammed **One Touch Call** button 

### **Making a Voice Call with the Channel Rocker**

#### **Making a Group Call**

To make a call to a group of users, your radio must be configured as part of that group.

#### **Procedure:**

- 1 Press the Channel Rocker to select the channel with the active group ID.

---

- 2 Press the **PTT** button to make the call. The green LED lights up.

---

- 3 Wait for the Talk Permit Tone to finish (if enabled) and speak clearly into the microphone.

---

- 4 Release the **PTT** button to listen. When the target radio responds, the green LED blinks.

---

- 5 If there is no voice activity for a predetermined period of time, the call ends.

---

## **Making a Private Call**

### **Procedure:**

- 1 Press the Channel Rocker to select the channel with the active subscriber ID.

---

- 2 Press the **PTT** button to make the call. The green LED lights up.

---

- 3 Wait for the Talk Permit Tone to finish (if enabled) and speak clearly into the microphone.

---

- 4 Release the **PTT** button to listen. When the target radio responds, the green LED blinks.

---

- 5 If there is no voice activity for a predetermined period of time, the call ends.

---

- 6 You hear a short tone.

---

## **Making an All Call**

This feature allows you to transmit to all users on the channel. Your radio must be programmed to allow you to use this feature.

### **Procedure:**

- 1 Press the Channel Rocker to select the channel with the active All Call group ID.

---

- 2 Press the **PTT** button to make the call. The green LED lights up.

---

- 3 Wait for the Talk Permit Tone to finish (if enabled) and speak clearly into the microphone.

---

*Users on the channel cannot respond to an All Call.*

## **Making a Group or Private Call with the One Touch Call Button**

The One Touch Call feature allows you to make a Group or Private Call to a predefined ID easily. This feature can be assigned to a short or long programmable button press.

You can **ONLY** have one ID assigned to a **One Touch Call** button. Your radio can have multiple **One Touch Call** buttons programmed.

### **Procedure:**

- 1 Press the preprogrammed **One Touch Call** button to make a Group or Private Call to the predefined ID.

---

- 2 Press the **PTT** button to make the call. The green LED lights up.

---

- 3 Wait for the Talk Permit Tone to finish (if enabled) and speak clearly into the microphone.

---

- 4 Release the **PTT** button to listen. When the target radio responds, the green LED blinks.

---

- 5 If there is no voice activity for a predetermined period of time, the call ends.

---

*For a Private Call, you hear a short tone when the call ends.*



## ■ Talkaround

---

You can continue to communicate when your repeater is not operating, or when your radio is out of the repeater's range but within talking range of other radios. This is called "talkaround".

### Procedure:

- 1 Press the preprogrammed **Repeater/Talkaround** button.
  - 2 You hear a positive indicator tone, indicating the radio is in Talkaround mode. The Talkaround icon is displayed.  
**OR**  
You hear a negative indicator tone, indicating the radio is in Repeater mode. The Talkaround icon is turned off.
- 

*The Talkaround setting is retained even after powering down.*

## ■ Permanent Monitor

---

Use the Permanent Monitor feature to continuously monitor a selected channel for activity.

### Procedure:

- 1 Press the preprogrammed **Permanent Monitor** button.
  - 2 Radio sounds alert tone, and the yellow LED lights up.
  - 3 Press the preprogrammed **Permanent Monitor** button to remove the radio from permanent monitor mode.
  - 4 Radio sounds an alert tone and the LED turns off,
-

## Advanced Features

Use this navigation guide to learn more about advanced features available with your mobile:

Scan Lists . . . . .	page 13
Scan . . . . .	page 13
Call Indicator Settings . . . . .	page 15
Call Alert Operation . . . . .	page 15
Emergency Operation . . . . .	page 16
Text Messaging Features . . . . .	page 18
Utilities . . . . .	page 19

### ■ Scan Lists

Scan lists are created and assigned to individual channels/groups. Your radio scans for voice activity by cycling through the channel/group sequence specified in the scan list for the current channel.

Your radio supports up to 32 scan lists, with a maximum of 16 members in a list. Each scan list shall support a mixture of both analog and digital entries.

### ■ Scan

When you start a scan, your radio cycles through the preprogrammed scan list for the current channel looking for voice activity.

The yellow LED blinks and you see the scan icon on the display.

During a dual mode scan, if you are on a digital channel, and your radio locks onto an analog channel, it automatically switches from digital mode to analog mode for the duration of the call. This is also true for the reverse.

There are two types of scans:

- **Main Channel Scan (Manual):** Your radio scans all the channels/groups in your scan list. On entering scan, your radio may – depending on the settings – automatically start on the last scanned “active” channel/group or on the channel where scan was initiated.
- **Auto Scan (Automatic):** Your radio automatically starts scanning when you select a channel/group that has Auto Scan enabled.

## Starting and Stopping Scan

### Procedure:

- 1 Press the preprogrammed **Scan** button.  
**OR**  
Use the Channel Rocker to select a channel with Auto Scan enabled.

---
- 2 When Scan is enabled, the yellow LED blinks and you hear a positive indicator tone. The scan icon is displayed.  
**OR**  
When Scan is disabled, the LED turns off and you hear a negative indicator tone. The scan icon is turns off.

---

## Responding to a Transmission During a Scan

During scanning, your radio stops on a channel/group where activity is detected. The radio stays on that channel for a preprogrammed time period known as “hang time”.

### Procedure:

- 1 Press the **PTT** button during hang time. The green LED lights up.

---
- 2 Wait for the Talk Permit Tone to finish (if enabled) and speak clearly into the microphone.

---
- 3 Release the **PTT** button to listen.

---
- 4 If you do not respond within the hang time, the radio returns to scanning other channels/groups.

---

## Deleting a Nuisance Channel

If a channel continually generates unwanted calls or noise (termed a “nuisance” channel), you can temporarily remove the unwanted channel from the scan list.

This capability does not apply to the channel designated as the Selected Channel.

### Procedure:

- 1 When your radio “locks on to” an unwanted or nuisance channel, press the preprogrammed **Nuisance Channel Delete** button until you hear a tone.

---
- 2 Release the **Nuisance Channel Delete** button. The nuisance channel is deleted.

---

## Restoring a Nuisance Channel

### Procedure:

To restore the deleted nuisance channel, do **one** of the following:

- Power the radio off and powering it on again, **OR**
- Stop and restart a scan via the preprogrammed **Scan** button, **OR**
- Change the channel via the Channel Rocker.

## ■ Call Indicator Settings

---

You can turn on or off the ringing tones for a received Private Call (see *Turning Radio Tones/Alerts On or Off* on page 20).

### Escalating Alarm Tone Volume

Your radio can be preprogrammed by your dealer to continually alert you when a radio call remains unanswered. This is done by automatically increasing the alarm tone volume over time.

This feature is known as Escalart.

## ■ Call Alert Operation

---

Call Alert paging enables you to alert a specific radio user to call you back when they are able to do so.

This feature is accessible via a preprogrammed **One Touch Call** button.

### Receiving and Acknowledging a Call Alert

#### Procedure:

When you receive a Call Alert page:

- 1 You hear a repetitive tone. The yellow LED blinks.
- 2 Press and release the **PTT** button to acknowledge the alert.

### Making a Call Alert with the One Touch Call

#### Button

#### Procedure:

- 1 Press the preprogrammed **One Touch Call** button to make a Call Alert to the predefined ID.
- 2 The green LED lights up when your radio is sending the Call Alert.
- 3 If the Call Alert acknowledgement is received, two chirps sounds.  
**OR**  
If the Call Alert acknowledgement is not received, a low-pitch tone sounds.

## ■ Emergency Operation

---

An Emergency Alarm is used to indicate a critical situation. You are able to initiate an Emergency at any time, in any state, even when there is activity on the current channel.

Your radio supports 3 Emergency Alarms:

- Emergency Alarm
- Emergency Alarm with Call
- Emergency Alarm with Voice to Follow 

In addition, each alarm has the following types:

- Regular – Radio transmits an alarm signal and shows audio and/or visual indicators.
- Silent – Radio transmits an alarm signal without any audio or visual indicators.

Only **one** of the Emergency Alarms above can be assigned to the preprogrammed **Emergency** button or the **Emergency** footswitch.

### Sending an Emergency Alarm

This feature allows you to send an Emergency Alarm, a non-voice signal, which triggers an alert indication on another radio.

### Procedure:

- 1 Press the preprogrammed **Emergency** button or the **Emergency** footswitch.

---
- 2 The green LED lights up.

---
- 3 When an Emergency Alarm acknowledgment is received, the Emergency tone sounds. The green LED blinks.  
**OR**  
If your radio does not receive an Emergency Alarm acknowledgement, and after all retries have been exhausted, a low-pitch tone sounds.

---
- 4 Radio exits the Emergency Alarm mode.

---

### Sending an Emergency Alarm with Call

This feature allows you send an Emergency Alarm to another radio. Upon acknowledgement, both radios can communicate over a preprogrammed Emergency channel.

### Procedure:

- 1 Press the preprogrammed **Emergency** button or press the **Emergency** footswitch.

---
- 2 The green LED lights up.

---
- 3 When an Emergency Alarm acknowledgment is received, the Emergency tone sounds. The green LED blinks.

---

- 4 Press the **PTT** button to make the call. The green LED lights up.
- 5 Wait for the Talk Permit Tone to finish (if enabled) and speak clearly into the microphone.
- 6 Long press the preprogrammed **Emergency** button to exit the Emergency mode.

### **Sending an Emergency Alarm with Voice to**

#### **Follow**

This feature allows you to send an Emergency Alarm to another radio. Upon acknowledgement, your radio's microphone is automatically activated, allowing you to communicate with the other radio without pressing the **PTT**.

This activated microphone state is also known as "hot mic".

If you press the **PTT** button during the preprogrammed hot mic transmission period, the radio ignores the **PTT** press and remains in Emergency mode.

**NOTE:** If you press the **PTT** button during hot mic, and continue to press it after the hot mic duration expires, the radio continues to transmit until you release the **PTT** button.

#### **Procedure:**

- 1 Press the preprogrammed **Emergency** button or the **Emergency** footswitch.
- 2 The green LED lights up.
- 3 Once a tone sounds, speak clearly into the microphone. When hot mic has been enabled, the radio automatically transmits without a **PTT** press until the hot mic duration expires.
- 4 While transmitting, the green LED lights up.
- 5 Once the hot mic duration expires, the radio automatically stops transmitting. To transmit again, press the **PTT** button.

### **Reinitiating an Emergency Mode**

There are two instances where this can happen:

- You change the channel while the radio is in Emergency mode. This exits the Emergency mode. If Emergency Alarm is enabled on this new channel, the radio reinitiates Emergency.
- You press the preprogrammed **Emergency** button during an Emergency initiation/transmission state. This causes the radio to exit this state, and to reinitiate Emergency.

## Exiting an Emergency Mode

Your radio exits Emergency mode when **one** of the following occurs:

- Emergency Alarm acknowledgement is received (for **Emergency Alarm** only), **OR**
- All retries to send the alarm have been exhausted, **OR**
- The preprogrammed **Emergency** button is long pressed (not applicable for **Emergency Alarm with Voice to Follow**).

**NOTE:** If your radio is powered off, it exits the Emergency mode. The radio will not reinitiate the Emergency mode automatically when it is turned on again.

## ■ Text Messaging Features

---

### Sending a Quick Text Message

You can send Quick Text messages, preprogrammed by your dealer, via the programmable button.

#### Procedure:

- 1 Press the preprogrammed **One Touch Call** button to send a predefined Quick Text message to a predefined ID.

---

- 2 The green LED lights up.

---

- 3 Two chirps indicate that the message is sent successfully.  
**OR**  
A low-pitch tone indicates that the message cannot be sent.

*Only applicable when sending to subscriber IDs:*

*You hear two chirps if the target radio successfully receives the Quick Text message.*

*OR*

*You hear a low-pitch tone if the target radio fails to receive the Quick Text message*

.

## ■ Utilities

---

### **Setting the Squelch Level**

You can adjust your radio's squelch level to filter out unwanted calls with low signal strength or channels that have a higher than normal background noise.

**Settings:** **Normal** is the default. **Tight** filters out (unwanted) calls and/or background noise. However, calls from remote locations may also be filtered out.

**Procedure:**

- 1 Press the preprogrammed **Squelch** button.
- 
- 2 You hear a positive indicator tone, indicating the radio is operating in tight squelch.  
**OR**  
You hear a negative indicator tone, indicating the radio is operating in normal squelch.
- 

### **Setting the Power Level**

You can customize your radio's power setting to high or low for each channel.

**Settings:** **High** enables communication with radios located at a considerable distance from you. **Low** enables communication with radios in closer proximity.

**Procedure:**

- 1 Press the preprogrammed **Power Level** button.
- 
- 2 You hear a positive indicator tone, indicating the radio is transmitting at low power.  
**OR**  
You hear a negative indicator tone, indicating the radio is transmitting at high power.
-



### Turning Horns/Lights On or Off

Your radio is able to notify you of an incoming call via the horns and lights feature. When activated, an incoming call sounds your vehicle's horn and turns on its lights.

This feature needs to be installed through your radio's rear accessory connector by your dealer.

#### Procedure:

- 1 Press the preprogrammed **Horns/Lights** button.

---
- 2 You hear a positive indicator tone, indicating the horns and lights feature is on.  
**OR**  
You hear a negative indicator tone, indicating the horns and lights feature is off.

---

### Turning Radio Tones/Alerts On or Off

You can enable and disable all radio tones and alerts (except for the incoming Emergency alert tone) if needed.

#### Procedure:

- 1 Press the preprogrammed **All Tones/Alerts** button.

---
- 2 You hear a positive indicator tone, indicating all tones and alerts are on.  
**OR**  
You hear a negative indicator tone, indicating all tones and alerts are off.

---



MOTOROLA and the Stylized M Logo are registered in the U.S. Patent and Trademark Office. All other product or service names are the property of their respective owners.

© 2007 Motorola, Inc.  
All rights reserved. March 2007.

[www.motorola.com/mototrbo](http://www.motorola.com/mototrbo)



6866575D05-A